

TYPE E

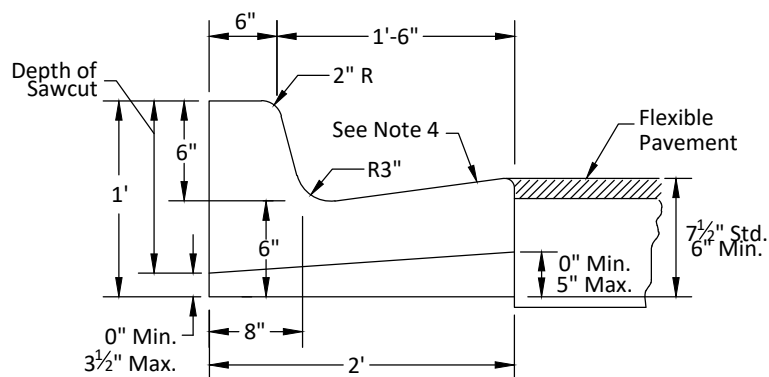

TYPE F

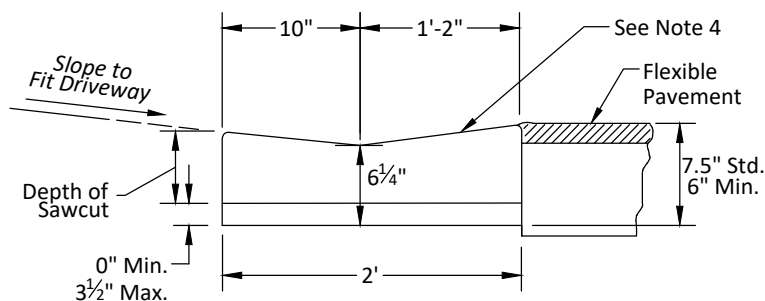

VALLEY GUTTER  
(DROP CURB)

Notes:

1. Ultimate strength of concrete for curbs shall be 2,500 psi. @ 28 days
2. 1/8" - 1/4" contraction joints in curb and gutter shall be cut as shown and at 10 ft. maximum spacing. No section shall be less than 4 ft.
3. When pavement is concrete, provide a 1/2" expansion joint with pre-formed joint filler & joint seal between curb and concrete pavement. (1 1/2" taper on curb face not required at concrete pavement).
4. When used on high side of roadways, the cross slope of the gutter shall match the cross slope of the adjacent pavement. The thickness of the lip shall be 6", unless otherwise shown on plans.

LATEST REVISION 2019	GENERAL CONSTRUCTION - CONCRETE CURB & GUTTER, CONT.	STANDARD DETAIL
	CITY OF WEST PALM BEACH - ENGINEERING SERVICES	GC-3